



Qlar

Empowering **steel excellence**

Weighing and feeding solutions
for your production processes



Driving **circular**
transformation

Safe, reliable and cost-effective solutions for your processes

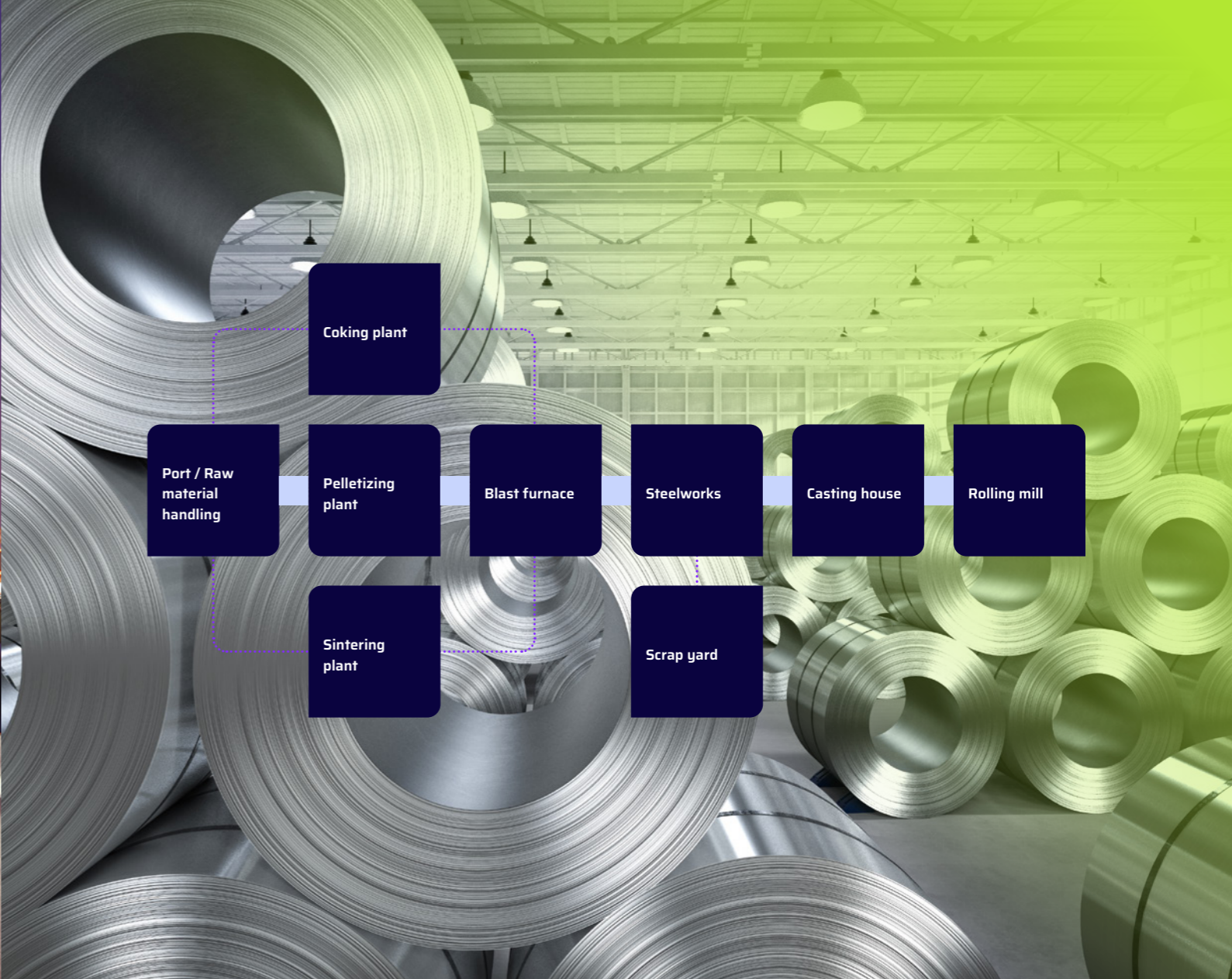

Qlar group Your partner worldwide

At Qlar, we understand that precision is the backbone of steel production. Our advanced measuring technology is designed to meet the rigorous demands of the steel industry, ensuring that every process is optimized for accuracy, efficiency, and quality.

With more than 140 years of experience and a commitment to innovation, we provide solutions that

help you achieve unparalleled results. From dosing, heavy load weighing, pneumatic injection and conveying: our engineered systems enable and improve nearly all the processes that take place during the production of steel.

Partner with us to enhance your production capabilities and stay ahead in a competitive market.

The steel industry from raw material to end product

Integrated steel works and electric steelworks all over the world rely on know-how and proven solutions from the Qlar group to ensure the smooth processing of huge quantities of material.

- Good cost-effectiveness and low energy consumption
- High quality
- High process reliability and availability
- Environmentally compatible production processes

These are the requirements demanded by the steel industry and its customers. For this reason every project is preceded by a requirements analysis to identify the equipment required, the necessary engineering services and the work required for installation and commissioning. The resulting action plan often produces innovative new solutions.

Coking plant

Example application

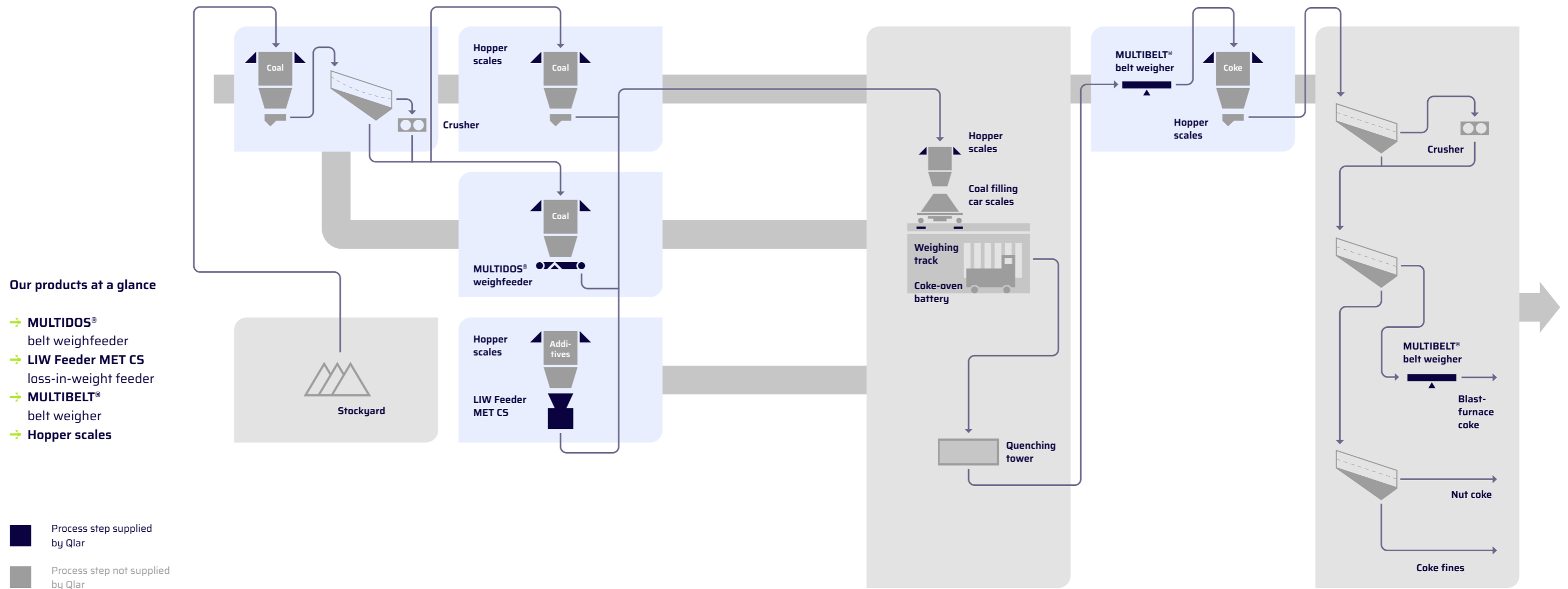

Efficient processes for maximum quality

In ore smelting, the coke as the reducing agent has an important influence on the cost-effectiveness of the process and the quality of the final product.

The quality of the coke depends on the mixture of different coal qualities used, the measurement of actual coal use in the coking plant and optimum classification with screening machines.

In the coal mixing plant, weighfeeders or discharge feeders extract different types of coal from the bunkers to form the mixture in accordance with a specified recipe.

Correct filling of the coke-oven batteries depends on the load cells that weigh the bunkers on the vehicle or weighing tracks in its path. These ensure a high level of accuracy and complete balancing, thus making sure that materials are used economically.

Pelletizing plant

Example application

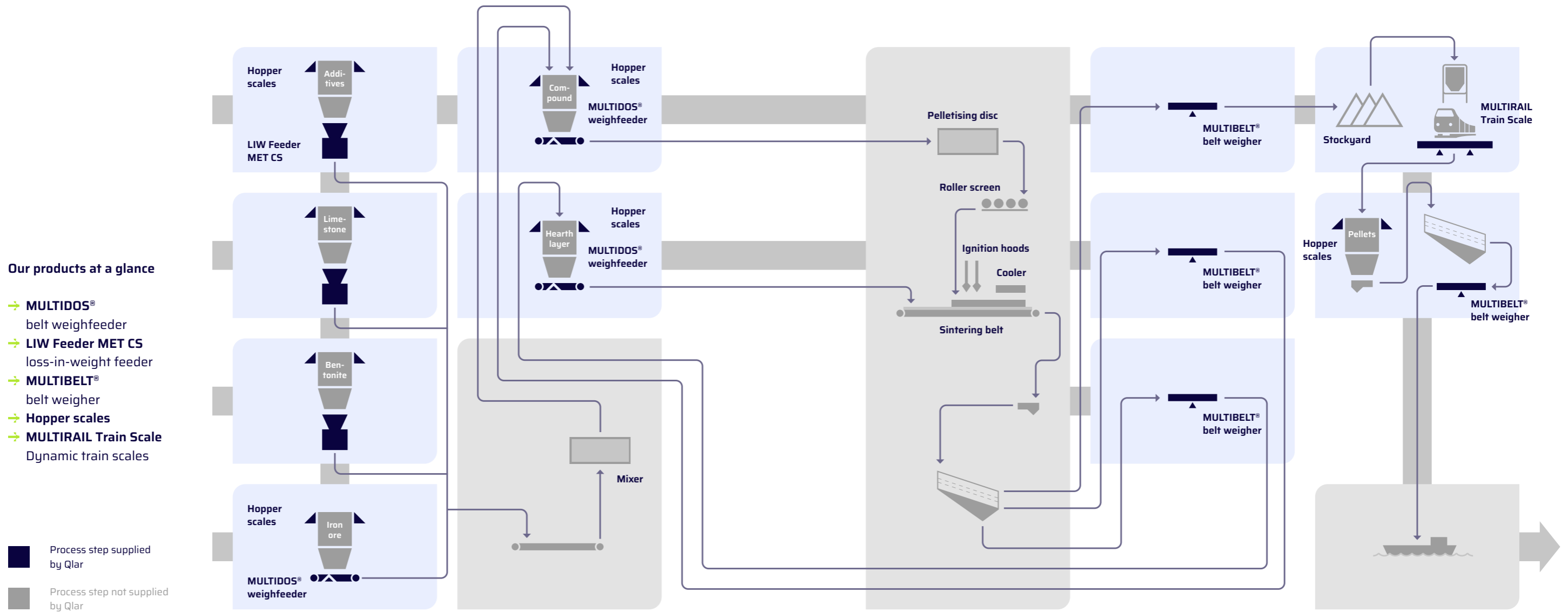

High precision all down the line

The equipment used to pelletise iron ore needs to be capable of conveying, feeding and mixing a wide range of materials under the toughest conditions. High handling speeds and high plant availability are both essential.

Here, Qlar solutions make a vital contribution to ensuring consistent quality and optimising the production process.

Qlar MULTIDOS® belt weighfeeders or LIW Feeder MET CS loss-in-weight feeders are used for continuous gravimetric feeding of all the materials required to make the pellet mix. Minimised investment and follow-on costs (operating and

maintenance costs), ease of installation and improved accuracy and quality of the end product are just some of the benefits that our products deliver.

Sintering plant

Example application

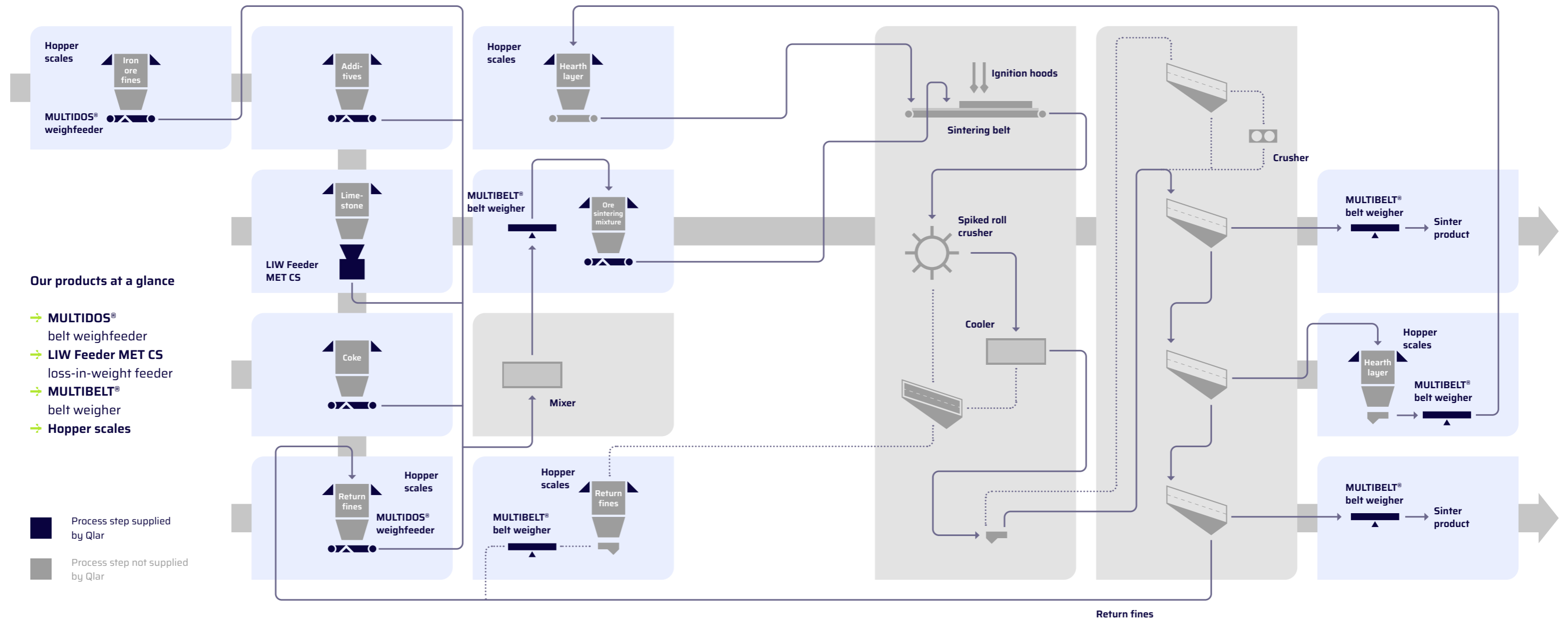

Solutions for stable processes

Achieving consistent quality in steel production requires a wide range of materials to be accurately conveyed, mixed and fed under the toughest conditions. High handling speeds and maximum availability of all components are essential.

Qlar solutions make a vital contribution to the optimisation of the production process.

Qlar MULTIDOS® belt weighfeeders or LIW Feeder MET CS loss-in-weight feeders are used for continuous gravimetric feeding of all the materials required to make the sintering mixture. Minimised investment and follow-on costs (operating and

maintenance costs), ease of installation and improved accuracy and quality of the end product are just some of the benefits that our products deliver.

Blast furnace

Example application

Our products at a glance

- ➔ **MULTIDOS®**
belt weighfeeder
- ➔ **MULTIBELT®**
belt weigher
- ➔ **Hopper scales**
- ➔ **MULTIRAIL Train Scale**
Torpedo train scales
- ➔ **Pulverised coal injection**
- ➔ **Top hopper scales**

- Process step supplied by Qlar
- Process step not supplied by Qlar

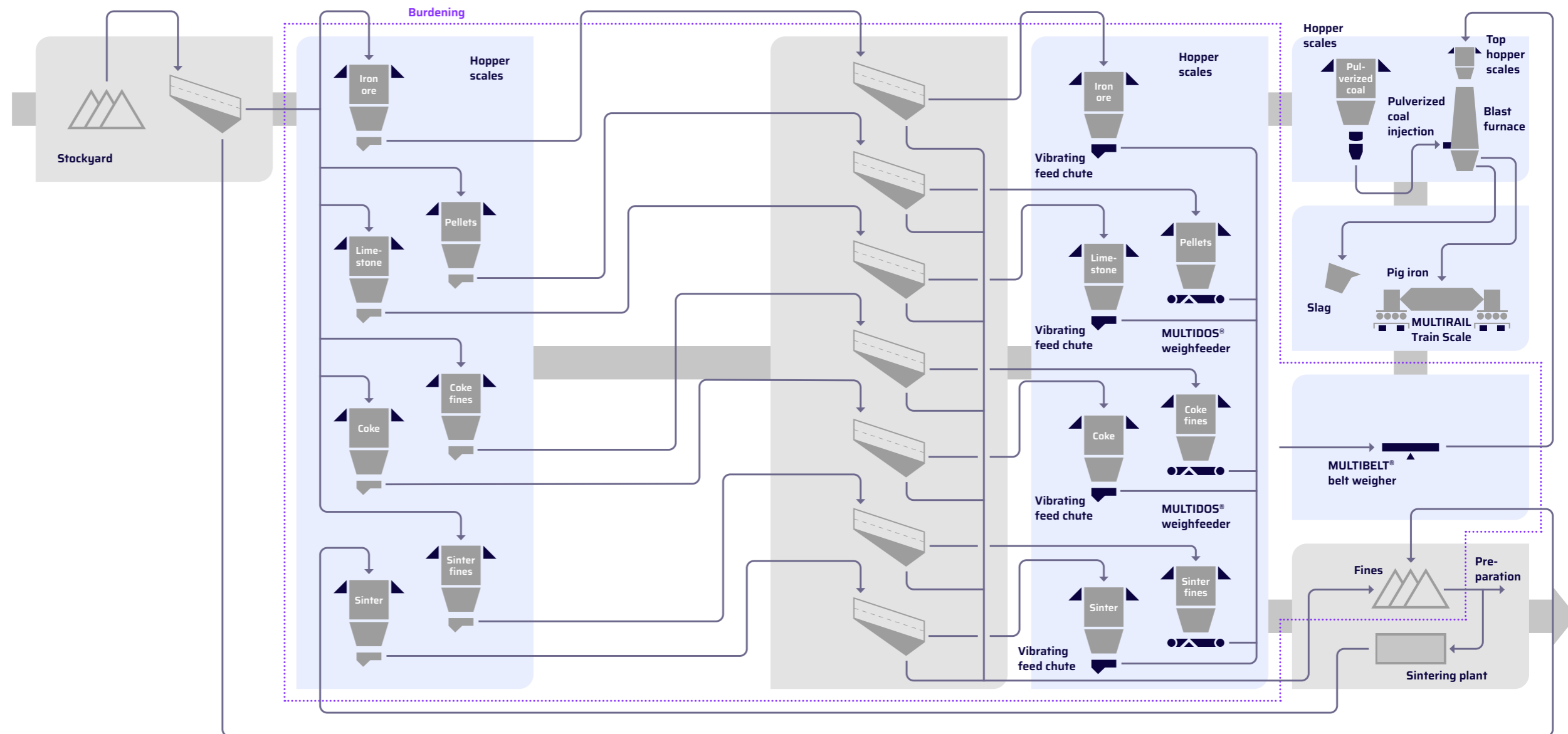

Focus on operating reliability

In the burdening process, stringent operating reliability and cost-effectiveness requirements apply.

This is where Qlar weighing systems, with their high precision, come in.

From level measuring equipment for the day bins to hopper scales for setpoint-controlled feeding and monitoring measuring equipment, Qlar makes operations and processes work reliably.

Our products also balance mass flows, both individually and in relation to upstream and downstream production units.



Scrap yard, steelworks, casting house, rolling mill

Example application

Our products at a glance

- ➔ Vibrating feed chutes
- ➔ MULTIDOS® belt weighfeeder
- ➔ Hopper scales
- ➔ Ladle ferry scales
- ➔ Scrap ferry scales
- ➔ Platform scales
- ➔ MULTIRAIL Train Scale
- ➔ Dynamic train scales
- ➔ MULTIRAIL Train Scale
- ➔ Torpedo train scales
- ➔ Crane scales
- ➔ Ladle turret scales
- ➔ Tundish scales
- ➔ Roller table scales
- ➔ Coil scales
- ➔ Platform scales for bar iron
- ➔ EAF weighing and condition monitoring system

- Process step supplied by Qlar
- Process step not supplied by Qlar

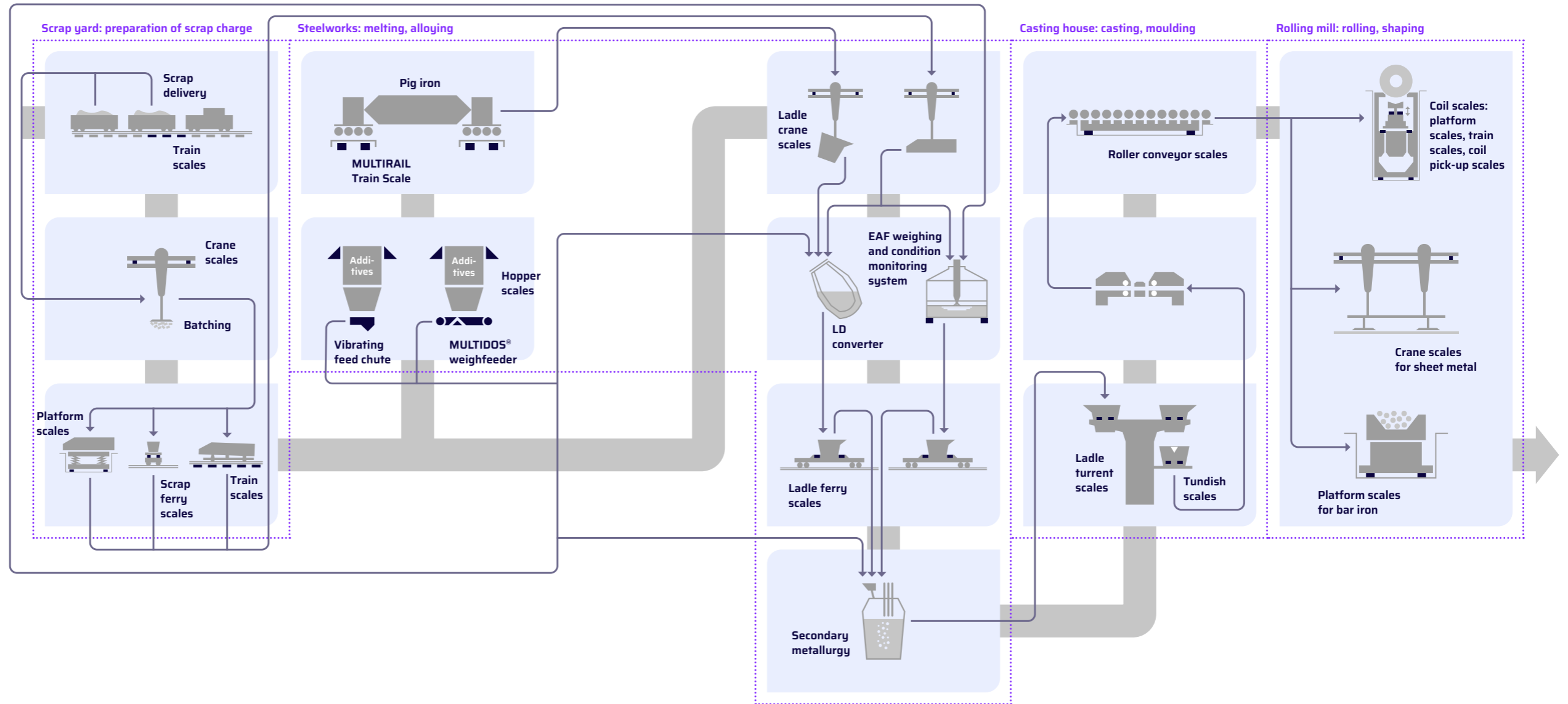

High-efficiency weighing and feeding technology for all relevant process stages

The global consolidation of the steel industry demands optimised processes. Weighing and feeding systems have always played an important part in economical and safe steel production: from the mass control and feeding of raw materials to the processing of pig iron and crude steel to the sale of the finished products.

The weighing and feeding systems used for internal control in the production area (scrap yard, blast furnace, converter, EAF and continuous casting machine) have to operate in a particularly harsh environment. They handle weights of 1 to 1,000 tonnes, sometimes at extreme temperatures.

The requirements are many and varied:

- ➔ Production control to achieve stable quality parameters
- ➔ Measuring and optimising production efficiency
- ➔ Internal cost allocation

Weighing and feeding systems from Qlar operate accurately, reliably and with little maintenance throughout their service life. Qlar develops, designs and manufactures direct weighing technologies for specially adapted load cells for steel production in house. This enables us to respond optimally to our customers' growing requirements.

Our product range for steel production

Weighing and feeding technology Maximum precision in bulk material handling

Weighing, feeding and conveying equipment handles a range of bulk materials from the finest to the toughest with very high accuracy. The harsher the environment, the more robust the technical systems need to be.

Qlar weighing modules, for example, calculate the highly precise addition of alloying agents in electric steelworks or the exact weight of a ladle weighing

several tonnes in a continuous casting plant. Intelligent weighing and feeding systems allow direct feeding and precise measurement. All logistics are handled by loading and automation systems.

Our weighing, feeding and conveying systems measure weight, force and material throughput. They offer robustness, precision and reliability - and are built to withstand the harshest conditions.

Feeding



MULTIDOS®
belt weighfeeder

- Feed rate up to 1,500 t/h
- Maximum accuracy $\pm 0.25\%$
- Long experience with many important industrial bulk materials



LIW Feeder MET CS
loss-in-weight feeder

- Safe discharge with integrated agitator
- Feed and extension hoppers made of acid- and corrosion-resistant steel
- Integrated measurement, control and monitoring electronics
- High feed accuracy and consistency, better than $\pm 0.5\%$



MULTICOR® K
Pulverised coal feeding

- Pulsation-free feeding
- High feed consistency = high process stability and efficient combustion
- Feeding independent of external factors
- Engineering, material discharge, feeding and measurement from one supplier

Weighing



MULTIBELT®
belt weigher

- Precise mass flow measurement
- Standard and customised versions available
- Accuracy up to $\pm 0.25\%$
- Optional: legal-for-trade design



Hopper scales

- For hoppers up to 3000 t
- Legal-for-trade accuracy
- Large overload capacity
- Maintenance-free design



Scrap ferry & ladle ferry

- Large overload capacity, easy installation, minimum maintenance
- High level of weighing accuracy:
 - up to $\pm 0.1\%$ of weighing range final value
 - up to $\pm 1\%$ of actual value of loaded scrap

Bring your steel production to the next level



Weighing



Platform scales or weighbridges

- Concrete or welded construction
- For heavy-duty vehicles up to 200 t
- Legal-for-trade accuracy



MULTIRAIL Train Scale

Dynamic train scales

- High-precision, legal-for-trade weighing
- Up to 15 km/h
- No need for foundations or interruption of track
- Temperature range of -30 °C to +70 °C



Crane scales

Pulverised coal feeding

- Precise weighing during working process
- Automatic weighing and simple operation
- Modular electronics and passive measuring elements
- Proven, hermetically encapsulated load cells or sensors
- Numerous successful examples of installation in trolley or spreader beam



Weighing sensors

- At a glance: ring-torsion load cells RTN, weighbeam WB and weighdisc WD
- Accuracies of $\pm 0.1\%$ up to maximum calibrated precisions of C5 class
- Rated loads of 130 kg to 600 t
- Service temperatures up to 180 °C
- Customised load cells from a single source



Weighing and feeding electronics

- Suited to measuring, controlling, feeding and feedback work in all industries
- Legal-for-trade design
- Temperature range -30 °C to +60 °C
- Scope for connecting up industrial fieldbuses
- Wireless communication via Bluetooth
- Clear user guidance on the backlit LCD with graphics

Receiving



IntraBulk®

Truck unloading

- Receiving buffer hopper and apron conveyor as link to the continuous process
- Dust extraction systems
- Quick discharge, safe operation



Qlar TestCenters worldwide

No matter what materials you use, processes need to run smoothly. When processing your products, if you want complete peace of mind that materials and machines are perfectly matched, realistic tests in our TestCenters are what you need.

Qlar operates TestCenters around the globe which are tailored to your individual challenges. Two of these centres are in Darmstadt. Additional test facilities can be found at our Locations in the UK and the Czech Republic.

Which feeder is best for which bulk material? What needs to be noted for pneumatic conveying and feeding? And what requirements do alternative fuels place on feeding and conveying systems?

The test results gained will help you determine optimum processes and thereby ensure successful production results.

Conveying



Mechanical conveying and MoveMaster® bulk conveying

- Tube belt conveyor
- U belt conveyor
- Corrugated belt conveyor
- Smooth material handling
- Horizontal transport and elevating
- Maintenance-optimised design
- Trough chain conveyor



Pneumatic conveying / injection

- For difficult (abrasive or fragile) materials
- For temperatures up to 450 °C
- Feed rates of over 300 t/h
- For distances over 2 km
- Low maintenance requirements

Service for your complete peace of mind

We design everything with long-term stability and maximum operational reliability in mind.

Whether we're doing a simple engineering study or a complete design-build project, at Qlar, everything we do is centered on customer satisfaction.

When it comes to your mission-critical processes, you need a partner you can rely on 100 % to keep your business operating optimally. At Qlar, we support our customers with fully tailored service concepts to guarantee complete peace of mind.

Our services, your advantages

- Industry experts with decades of experience
- Global test and innovation centers for feeding, weighing and conveying
- Dedicated application support
- Product engineering design
- Global manufacturing & engineering
- Installation and commissioning
- Global product & operation training
- Remote, digital support services for testing and aftersales



Martin Brauer
Technical Sales Manager
Weighing & Feeding, EMEA

+49 6151 1531 3625
 m.brauer@qlar.com

The Qlar Group is a global leader in industrial weighing and feeding technology for bulk material, pneumatic and mechanical materials handling & automation and diagnosis technology.

Qlar

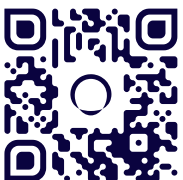

Still questions? Contact us:
www.qlar.com/contact

09.24 · All information is given without obligation.
All specifications are subject to change.

Brochure number BV-P 2114 EN
© Qlar, 2024

Qlar Europe GmbH
Pallaswiesenstraße 100
64293 Darmstadt, Germany

T: +49 61 51-15 31 0

sales-eu@qlar.com
www.qlar.com