

Slope correction system for variable weigher inclination

- Suitable for any scales, e.g. belt weighers
- Inclination correction: bis $\pm 29^\circ$
- Robust design, IP65



Application

The inclination correction device VME 28061 is used to correct the measuring signal of a weighing system when the inclination varies. The device is used primarily in belt weighers.

Design

The device measures the inclination electronically and corrects the signal from the load cell accordingly. It is enclosed in a housing with IP65 protection. It is attached at a point that experiences the same tilt as the scale to be corrected.

The device is roughly aligned with the mechanism. The fine adjustment is done electronically.

Function

A tilted scale measures only a reduced weight of the mass to be measured, using the cosine of the angle. The VME 28061 inclination correction device corrects this error at the reference measurement of a strain-gauge load cell.

The correct functioning is independent of the type and number of load cells. The design of the measuring electronics is not important for correct functioning as long as the supply voltage of the load cell does not exceed 12 V.

Measurement error without correction device

Inclination	Faulty reading
2.5°	-0.1 %
5.0°	-0.4 %
10.0°	-1.5 %
15.0°	-3.4 %
20.0°	-6.0 %

Note: If the scales are inclined without a correction device, the measured dead load will change. This also will cause absolute measuring errors when determining the payload.

Technical Data

Slope range	-29° ... +29° from the horizontal in exactly one inclination plane
Residual correction error in the operating temperature range	< 0.05 % of the measured value of the load cell
Supply voltage	18 ...36 VDC (The potential separation is done in the VME 28061)
Load cell supply voltage	12 Vpp AC or DC maximum
Operating temperature range	-25 °C ... +60 °C Avoid direct sunlight
Storage temperature range	-40 °C ... +80 °C
Signal wire cable cross-section	Max. 1.5 mm ²
Supply voltage cable cross-section	Max. 2.5 mm ²
Dimensions W x H x D [mm] (without cable inlets)	122 x 120 x 90
Weight	1500 g
Approbation	CE

Connection example

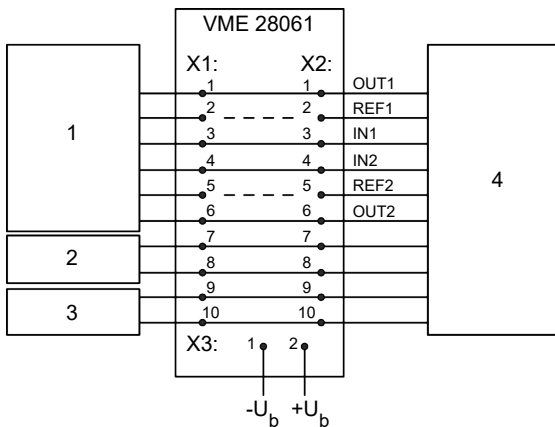

- 1 Load Cell
- 2 Tachometer 1
- 3 Tachometer 2
- 4 Weighing electronics

Dimension

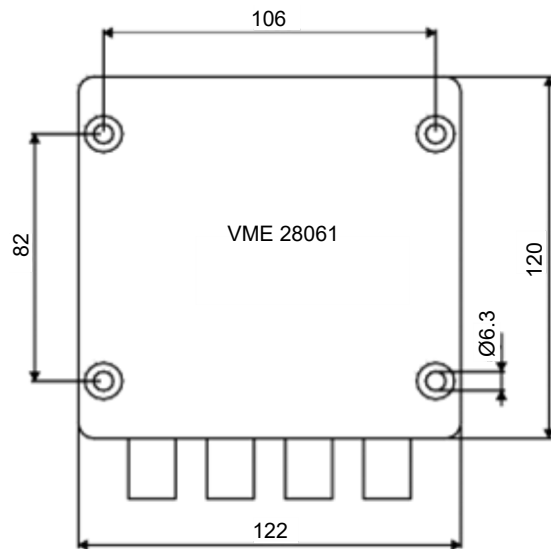

All dimensions in [mm]

